

This Development is managed by:

NRM Ltd

For information or advice:

Contact: 01473 558400

ranelaghroad@nrmltd.co.uk



NRM LTD
**Residential Managing Agents
& Property Maintenance**
Wherry Road, Norwich, NR1 1WS
Office: 01473 558400
ranelaghroad@nrmltd.co.uk
www.ranelaghroad.com or www.nrmltd.co.uk

NOTICE (August 2012): Communal TV Set-Up

SKY Subscriber Setup (Not Sky+)

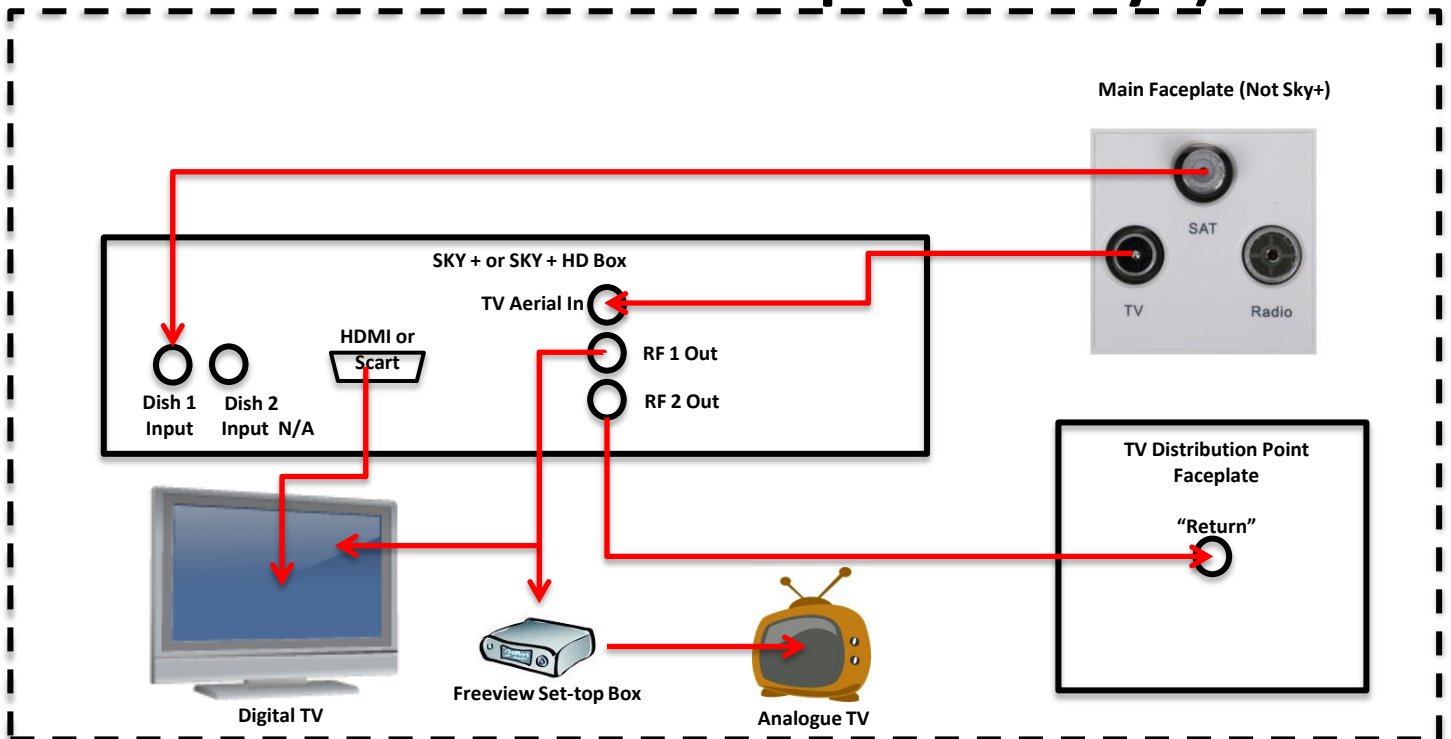

This setup enables Sky service in lounge / Freeview in bedroom AND Sky will also rebroadcast on Channel 68 (default set-up) (Google "Sky RF2 settings" for help)

Terrestrial Freeview Only Setup

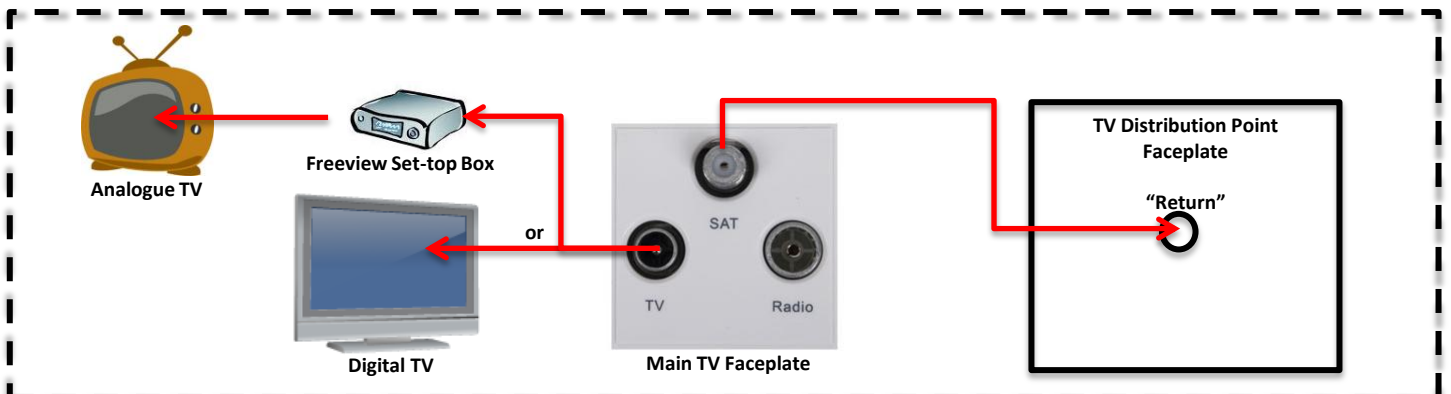

This setup enables Freeview in lounge /bedroom or an option for Freesat in bedroom.